

### GWK mobile work shop cranes

V

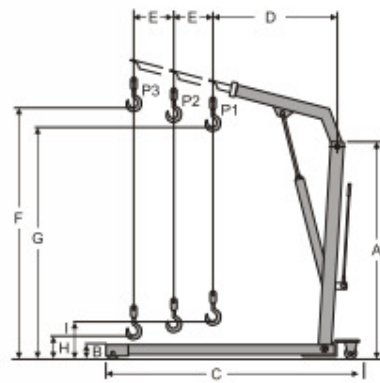

#### Properties

- Easy functioning.
- Quick lifting due to the double-acting pump.
- Collapsible, readily transportable.
- Robust construction.
- Chrome-plated hydraulic cylinder.
- Caster wheels can be rotated in 360°.
- Rotatable load hook (except when being under load).
- Gib can be set in 3 positions.
- 125% test load.
- Safety valve for overload prevention.
- Model GWK-1000 is equipped with extra-long supporting legs.



type	ref. no.	safe working load (kg)	safe working load per position (kg)			dimensions in mm										weight (kg)
			P1	P2	P3	A	B	C	D	E	F	G	H	I	width	
GWK- 500	4220015	500	500	425	350	1410	165	1510	895	102	2120	1960	150	340	970	75
GWK-1000	4220017	1000	1000	800	700	1675	90	1630	1230	150	2445	2330	-	245	1120	115
GWK-2000	4220019	2000	2000	1700	1500	1690	205	1900	1290	150	2705	2505	-	230	1165	165

### GWKE euro shop cranes

V

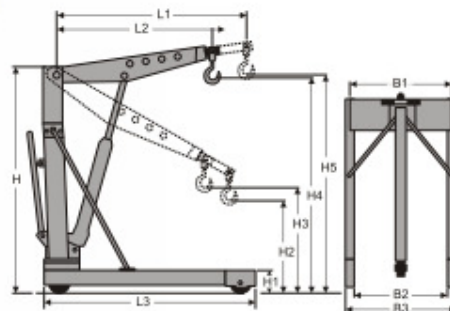

#### Properties

- Suitable for use with Euro pallets.
- Easy functioning.
- Robust construction.
- Chrome-plated hydraulic cylinder.
- Caster wheels can be rotated in 360°.
- Rotatable load hook (except when being under load).
- Gib can be set in 4 positions.
- 125% test load.
- Safety valve for overload prevention.

type	ref. no.	safe working load (kg)	safe working load per position (kg)				dimensions in mm											weight (kg)	
			P1	P2	P3	P4	L1	L2	L3	H1	H2	H3	H4	H5	H	B1	B2		B3
GWKE- 500	4220011	500	500	400	250	150	1360	1060	1295	155	470	705	2225	2475	1595	925	840	1000	80
GWKE-1000	4220013	1000	1000	800	500	300	1360	1060	1295	155	470	705	2225	2475	1595	925	840	1000	98